

ATLAS PLUS COMMERCIAL

LED Floodlight 80W 4000K

Part Code: **18068**

PHOEBE
LED

Technical Data Sheet



General

Part Code:	18068
Product Name:	Atlas Plus Commercial LED Floodlight 80W 4000K
Voltage:	220-240V
Norminal Wattage:	80W
Luminous Flux:	11050lm
Beam Angle:	100°
Lifespan:	50,000hrs
Dimmable:	Non-Dim

Electrometry

Rated Wattage (0.1W Precision):	80.0W
Voltage:	220-240V
Operating Frequency:	50/60Hz
Power Factor λ :	>0.9
Operating Current:	347.826086956522mA
Weighted Energy Consumption:	80W

Photometry

Rated Beam Angle:	100°
Rated Total Luminous Flux:	11050lm
Colour Temperature:	4000K
Colour Name:	Cool White
Colour Rendering Index:	≥ 80
Lumen Maintenance Factor:	0.95
Efficiency:	138lm/W

Dimensions

Length:	235mm
Height:	260mm
Depth:	60mm
Weight:	2.66kg

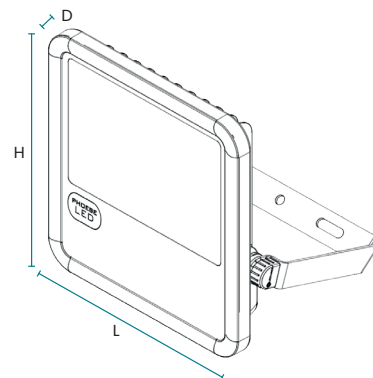

What to find out more?

Check out more info at cromptonlamps.com



Scan for more
information online

01274 657 088
01274 657 087
info@cromptonlamps.com
cromptonlamps.com

Crompton Lamps Limited
Unit 2, Marrtree Business Park,
Bowling Back Lane,
Bradford,
BD4 8QE

Crompton
Lamps

ATLAS PLUS COMMERCIAL

LED Floodlight 80W 4000K
Part Code: **18068**

PHOEBE
LED

Technical Data Sheet



Mechanical

Housing Material:	Tempered Glass/Die-Cast Aluminium/Polycarbonate
Ingress Protection Code:	IP65
Impact Protection Rating:	IK08
Appliance Class:	I
Mercury (Hg) Content:	0.0mg
Ambient Operating Temperature:	-20°C to 45°C

Packaging

EAN13 Barcode:	5055579318068
Single Carton Length:	35cm
Single Carton Width:	25.5cm
Single Carton Height:	6.5cm
Single Carton Volume:	5801.25cm ³
Single Carton Weight:	2.76KG

Life Span

Rated Life:	50,000 hours
Switching Cycles:	25,000
Rated Lamp Survival Factor:	0.9
Warranty:	5 years

Standards & Approvals

Manufactured in Accordance to:	BS EN 60598-2-1:2021
CE Mark:	Yes
UKCA Mark:	Yes
Country of Manufacture:	China
WEEE Recycling Verification:	Yes
Certificate of Conformity:	Available on Request
Accredited Members:	LIA

What to find out more?

Check out more info at cromptonlamps.com



Scan for more
information online

01274 657 088
01274 657 087
info@cromptonlamps.com
cromptonlamps.com

Crompton Lamps Limited
Unit 2, Marrtree Business Park,
Bowling Back Lane,
Bradford,
BD4 8QE

Crompton
Lamps