

# ATLAS PLUS COMMERCIAL

LED Floodlight 165W 4000K  
Part Code: **18082**

PHOEBE  
LED



## Technical Data Sheet

### General

Part Code:	18082
Product Name:	Atlas Plus Commercial LED Floodlight 80W 4000K
Voltage:	220-240V
Norminal Wattage:	165W
Luminous Flux:	21450lm
Beam Angle:	100°
Lifespan:	50,000hrs
Dimmable:	Non-Dim

### Electrometry

Rated Wattage (0.1W Precision):	165.0W
Voltage:	220-240V
Operating Frequency:	50/60Hz
Power Factor $\lambda$ :	>0.9
Operating Current:	717.391304347826mA
Weighted Energy Consumption:	165W

### Photometry

Rated Beam Angle:	100°
Rated Total Luminous Flux:	21450lm
Colour Temperature:	4000K
Colour Name:	Cool White
Colour Rendering Index:	$\geq 80$
Lumen Maintenance Factor:	0.95
Efficiency:	130lm/W

### Dimensions

Length:	418mm
Height:	322mm
Depth:	60mm
Weight:	4.56kg

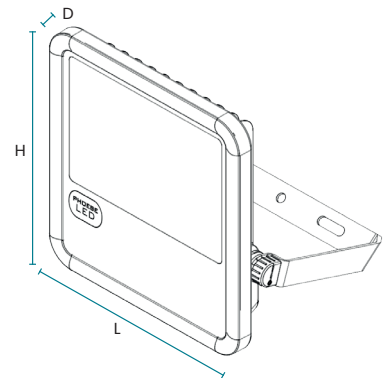

## What to find out more?

Check out more info at [cromptonlamps.com](http://cromptonlamps.com)



Scan for more  
information online

- 01274 657 088
- 01274 657 087
- [info@cromptonlamps.com](mailto:info@cromptonlamps.com)
- [cromptonlamps.com](http://cromptonlamps.com)

- Crompton Lamps Limited**  
Unit 2, Marrtree Business Park,  
Bowling Back Lane,  
Bradford,  
BD4 8QE

**Crompton**  
Lamps

# ATLAS PLUS COMMERCIAL

LED Floodlight 165W 4000K  
Part Code: **18082**

PHOEBE  
LED



## Technical Data Sheet

### Mechanical

Housing Material:	Tempered Glass/Die-Cast Aluminium/Polycarbonate
Ingress Protection Code:	IP65
Impact Protection Rating:	IK08
Appliance Class:	I
Mercury (Hg) Content:	0.0mg
Ambient Operating Temperature:	-20°C to 45°C

### Packaging

EAN13 Barcode:	5055579318082
Single Carton Length:	46cm
Single Carton Width:	33cm
Single Carton Height:	9cm
Single Carton Volume:	13662cm <sup>3</sup>
Single Carton Weight:	4.9KG

### Life Span

Rated Life:	50,000 hours
Switching Cycles:	25,000
Rated Lamp Survival Factor:	0.9
Warranty:	5 years

### Standards & Approvals

Manufactured in Accordance to:	BS EN 60598-2-1:2021
CE Mark:	Yes
UKCA Mark:	Yes
Country of Manufacture:	China
WEEE Recycling Verification:	Yes
Certificate of Conformity:	Available on Request
Accredited Members:	LIA

## What to find out more?

Check out more info at [cromptonlamps.com](http://cromptonlamps.com)



Scan for more  
information online

01274 657 088  
01274 657 087  
[info@cromptonlamps.com](mailto:info@cromptonlamps.com)  
[cromptonlamps.com](http://cromptonlamps.com)

**Crompton Lamps Limited**  
Unit 2, Marrtree Business Park,  
Bowling Back Lane,  
Bradford,  
BD4 8QE

**Crompton**  
Lamps